



Fig. 1



Fig. 2
The screen is bonded on its entire circumference (360°). The upshot is a low-resistant live connection between the screen, gland and housing.

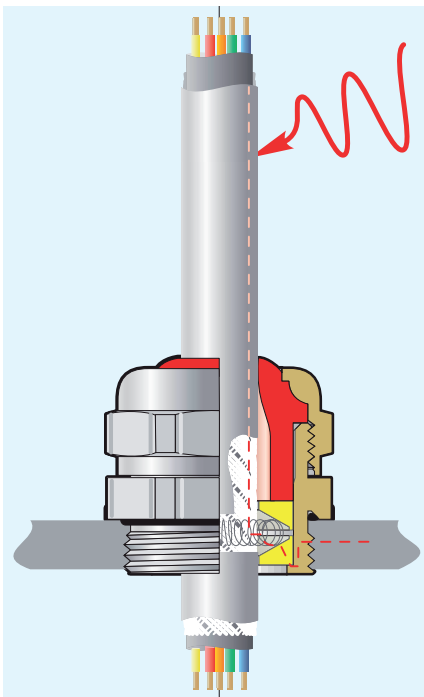

Fig. 3

Catalogue:
UNI EMC

EMC cable glands

EU Directive Electromagnetic Compatibility

Modern products are becoming increasingly more complex and more efficient. The demands for easy operation, functionality and operational safety with progressive miniaturisation at the same time can only be met by cutting-edge electronics being implemented. This means that the number of products with electrical and electronic components with high frequencies in private, commercial and above all in the industrial sectors is growing. Simultaneously, the spatial distances of the electronic systems are constantly diminishing.

This development is considerably raising the hazard of the functionally jeopardising impact of systems on each other through electromagnetic fields.

Any product fitted with electrical and electronic components can emit electromagnetic interference energy (source) or may be affected in its function by the action of electromagnetic interference energy from other items of equipment in its vicinity (sink).

The perpetrators of periodic continuous interference in the form of high-frequency electromagnetic fields in the frequency range of up to a few hundred MHz are, for example, PLCs (cycle frequency), fast PCs, cellular telephones, rectifiers, frequency converters, fast switchgear, motors, switching power packs. Pulsed interference is generated when switching inductance in low-voltage systems, by

power control units and switch drives, high-frequency welding plants and switching fluorescent lamps with frequencies in the MHz range.

The demand for securing electromagnetic compatibility – EMC – of various systems amongst each other requires legal provisions as well as technical rules and regulations in the form of standards.

EU Directive Electromagnetic Compatibility

The “Directive of the Council of the European Economic Area for the Harmonisation of Statutory Regulations of the Member States concerning Electromagnetic Compatibility 89/336 EEC dated 3rd May 1989” together with the two amendments 92/31 EEC dated 28.04.1992 and 93/68 EEC dated 22.07.1993 enabled objectives in the field of electromagnetic compatibility and the corre-

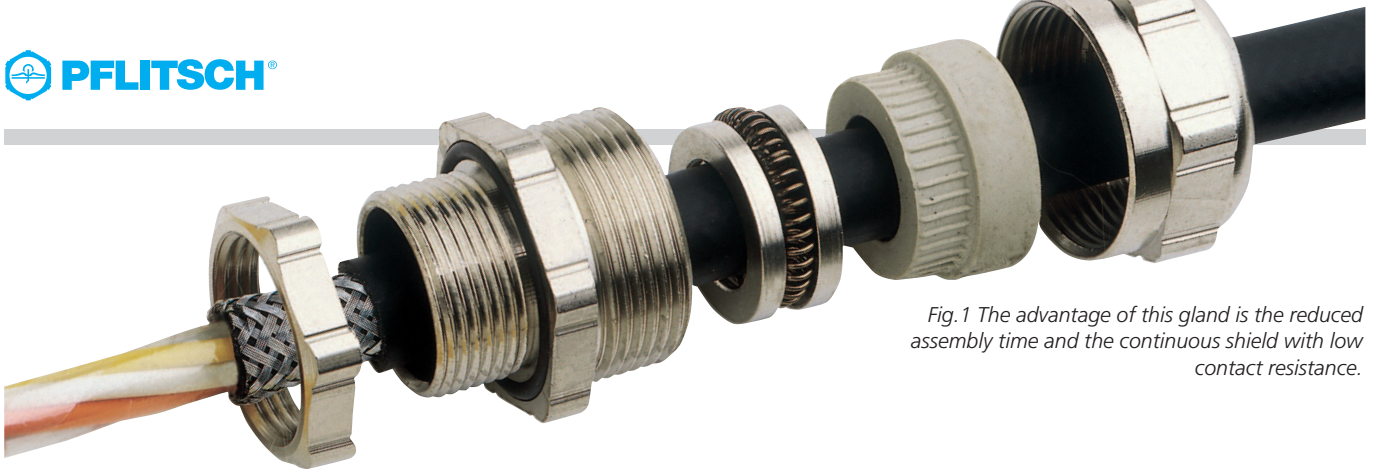

Fig. 1 The advantage of this gland is the reduced assembly time and the continuous shield with low contact resistance.

sponding market controls for maintaining this directive to be defined for all member states for the first time. This EU directive has been valid since 01.01.1996. All members of the EU have had to align their national legislation.

EU directive 89/366 EEC was completely revised and published as the new EU directive 2004/108 EC on 15.12.2004. This directive must be translated into national law by 20.07.2007. Directive 89/366 EEC will become invalid on the same day.

Act concerning Electromagnetic Compatibility of Equipment (EMCG)

Directive 89/366 EEC was realised for the Federal Republic of Germany by the "Act concerning the Electromagnetic Compatibility of Equipment (EMCG) dated 18th September 1998, 2nd Amendment – EMCG". In its first version, this act has been in force since 1st January 1996.

The Federal Government must translate the new EU Directive 2004/108 EC into a new EMC Act (EMCG) by 20.07.2007. There is a draft of the EMCG, which must come into force and be published as an EMC Act by, at the latest, 20.07.2007. This new act shall be valid for all equipment, which may cause electromagnetic interference or whose operation may be affected by electromagnetic interference. Observance of the EMC Act shall be monitored by the Federal Network Agency.

Stipulations are laid down in the EMC Act concerning:

- the field of application,
- the definitions,
- the fundamental protective requirements,
- the placing on the market,
- the initial operation and subsequent operation,
- the conformity appraisal procedure for equipment,
- CE identification,
- other characteristics and information,
- the appointed placement,
- the assignments, responsibilities and powers of the Federal Network Agency,
- the measures of the Federal Network Agency against market infringement.

To comprehend the further text better, due reference is herewith made to the definitions of EU Directive 2004/108 EC and the draft of the EMC Act 2007.

The protective requirements made on the equipment are defined in the EMC Act (EMCG):

The equipment must be procured in such a manner that with installation according to instructions, adequate maintenance and operation in accordance with the manufacturer's stipulations in the instructions for use

1. generation of electromagnetic interference is limited to the extent that intended operation of radio and telecommunication equipment as well as other equipment is possible.
2. the equipment shows adequate resistance to electromagnetic interference, so that operation as intended is possible.

The EMC Act does not contain any data concerning the admissible electro-technical limiting values, due reference being made to the harmonised European standards (EN Standards).

Basic specialist standards		
EN 61000-6-1:2001	VDE 0839-6-1 :2002-08	Electromagnetic compatibility (EMC) Basic specialist standard – interference resistance living areas, business and commercial areas as well as small enterprises
EN 61000-6-2:2005	VDE 0839-6-2 :2006-03	Electromagnetic compatibility (EMC) Basic specialist standard – interference resistance for industrial areas
EN 61000-6-3:2004	VDE 0839-6-3 :2005-06	Electromagnetic compatibility (EMC) Basic specialist standard – interference emission for living areas, business and industrial areas as well as small enterprises
EN 61000-6-4:2001	VDE 0839-6-4 :2002-08	Electromagnetic compatibility (EMC) Basic specialist standard – interference emission for industrial areas

Harmonised EN standards

The standards passed by the European Standards Committees CENELEC and ETSI and published in the EU Official Journal are thus binding for all EU countries. All pertaining national standards must then be revoked.

EN standards are subdivided into the spheres

- Basic specialist standards
- Standards of measurement processes
- Product family standards

The basic specialist standards define the requirements for interference emission and interference resistance for the living area, business and commercial areas as well as for small enterprises and the industrial field.

To the extent that product standards are available, they are to be preferentially applied.

In the standards to measurement procedures, the measuring instruments, the measurement set-up and the measurement environment for EMC measurements are described.

Certain products have their own EN standards, such as, for example:

- cable distribution systems for sound and television broadcasting signals,
- electrical system technology for homes and buildings,
- non-interruptible power supply systems,
- alarm systems,
- arc welding machines,
- household appliances,
- equipment with electromotive drive,
- electric heating equipment,
- power tools,
- lighting installations.

CE identification

When a manufacturer meets the EN standards that affect his equipment, it is accepted that he observes the protective requirements of the EMC Act. He may then issue an EC conformity declaration for his equipment on his own responsibility and the equipment must be provided with CE identification.

In as much as there are no EN standards, the manufacturer must call in a responsible agency for inspecting his product for observance of the protec-

tive requirements in accordance with the EMC Act. Once this examination has proved positive, the manufacturer may issue an EC conformity declaration and provide the equipment with CE identification. With this CE identification, the manufacturer also documents observance of further EC standards that apply to his product, e.g. the Low-Voltage Directive 73/23 EEC.

Source of interference

Differentiation is made between:

System-extraneous sources of interference, such as lightning discharges, electrostatic discharges, technical electromagnetic processes, from which periodically narrow or broad-band low, medium or high-frequency continuous interference in a frequency range from a few Hertz up to some 100 GHz. This includes, for example, all A.C. and three-phase circuits in power engineering, converter installations, HV and LV cable and line installations, electric motors, fluorescent lamps, switching power supply units, ignition systems for internal combustion engines, welding plants and naturally all telecommunication installations.

System-imminent sources of interference, such as the 50 Hz supply voltage, potential changes to the electronic lines, rapid signal changes on control and data lines, high and low-frequency cycle signals, power downs of inductances, spark discharges when opening and closing contacts, signal noise of active and passive components, chatter effects of contacts.

Electromagnetic interference may be caused grid-bound or by electrical and magnetic fields (interference radiation).

Filters and excess voltage limiters are implemented to restrict the grid-bound interference to the admissible limiting values. Shields are used to weaken interference by electrical, magnetic, electromagnetic fields.

Product family standards

	Interference emission	Interference resistance
Electrical measuring, control, and laboratory equipment	EN 61 326 VDE 00843-20-1	EN 61 326 VDE 00843-20-1
Radio, television sets	EN 55 013 VDE 0872-13	EN 55 020 VDE 0872-20
Household appliances, power tools,	EN 55 014-1 VDE 0875-14-1	EN 55 014-2 VDE 0875-14-2
Fittings for illumination purposes	EN 55 015 VDE 0875-15-1	EN 61 547 VDE 0875-15-2
Audio, video and audio-visual equipment	EN 55 103-1 VDE 0875-103-1	EN 55 103-2 VDE 0875-103-2
Information technology Audio-visual equipment	EN 55 022 VDE 0878-22	EN 55 024 VDE 0878-24

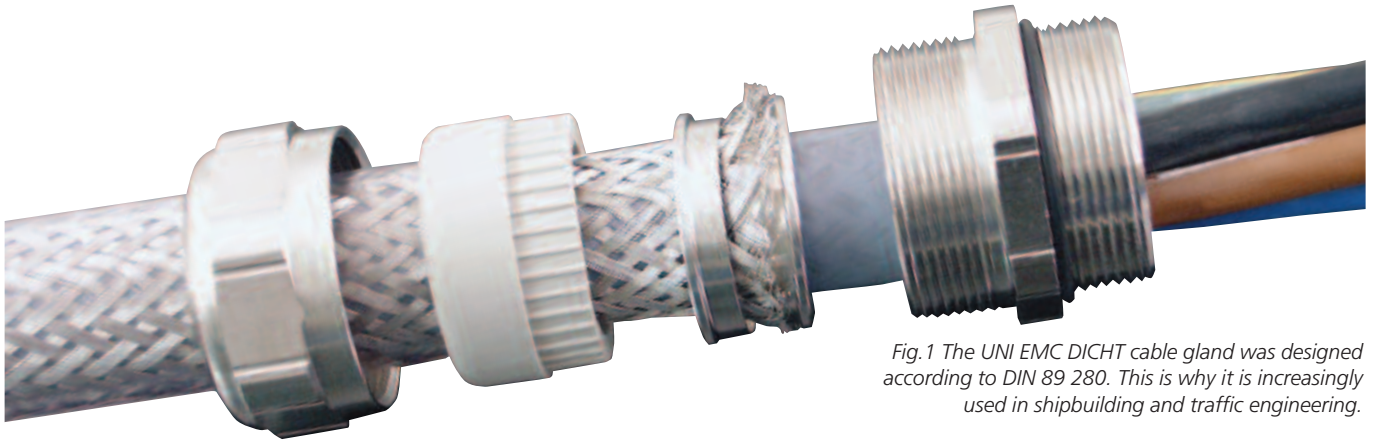

Fig.1 The UNI EMC DICHT cable gland was designed according to DIN 89 280. This is why it is increasingly used in shipbuilding and traffic engineering.

Shields

Shields have the job, on the one hand, of preventing penetration and interference by fields in modules, assemblies, equipment, cables and on the other hand of avoiding emission of these fields and the thus concomitant interference from electrical and electronic plant and equipment.

The shield effect depends on the following factors:

Material, frequency, electromagnetic type of wave, electrical conductivity of the surfaces, contact resistance.

The housings or enclosures used to protect electronic equipment offer certain protection against electromagnetic interference fields from penetrating or emitting, however, the shield effect is greatly limited against interference in the high-frequency range >100 MHz through existing slots, joints, cable break-throughs. The penetration factor of the fields is dependent on the type of field and on the size and geometry of the openings. In order to increase the shield effect, all slots, joints as well as all cables and cable lead-ins must be effectively sealed against electromagnetic fields.

The shield effect of a housing can be described by the shielding effectiveness a_s and the coupling resistance R_k .

Shielded lines

As protection against electromagnetic interference of electrical connections, shielded lines are generally used today, where they are necessary, with a screened braid made of thin copper wires with as high as possible optical spread. The EMC effect of a cable screen is largely dependent on its bonding on the housing and its earthing, one-sided or on both sides.

On entry and exit of screened cables, the screen effect of a housing must not be affected. It is recommended to expose the screen directly on the entry point and using an EMC cable and cable lead-in to connect it to the reference potential surface, at the same time this housing opening is "sealed" against the electromagnetic field.

EMC cable and cable lead-ins

The connection of the cable screen and housing must have as low an ohmic and inductive resistance as possible, the latter is frequency-dependent. Annular 360° bonding of the cable screen and the short connection to the housing via the connecting thread enable this low contact resistance to be attained.

With all environmental influences, such as temperature, moisture, dust, etc., the EMC cable gland must guarantee as low-resistant contact resistance as possible to the earthed housing wall.

Schirmdämpfung	Störreduktion	
dB	in %	um Faktor
0	0	1
20	90	10
40	99	100
60	99,9	1.000
80	99,99	10.000
100	99,999	100.000
120	99,9999	1.000.000

Should you have any questions regarding our EMC cable glands, please get in touch with us:

PFLITSCH GmbH & Co. KG
Mühlenweg 30
D - 42499 Hückeswagen
Tel: +49 (0) 2192 / 911- 0
Fax: +49 (0) 2192 / 911- 220
www.pflitsch.de
E-Mail: info@pflitsch.de