

# 8TFLT/8TFD



## Applications

- Military
- Aeronautical

## Standards

- 8TFLT : MIL-C 38999 Series I  
NFC 93422 HE 308  
DTAT C 5935 x 0001
- 8TFD : MIL-C 38999 Series III

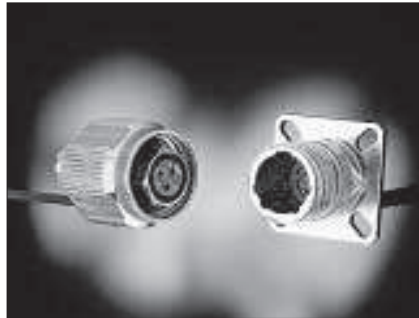

## Description

8TFLT and 8 TFD filter connectors are equipped with planar arrays filters. These connectors have the same length as the standard connectors of the same series so as to be directly interchangeable, and allow an easy implementation of the filtering at all stage of equipment development and life.

## Characteristics

### Mechanical

- Shells : aluminum alloy, olive green cadmium or nickel plated
- Insulators : thermoplastic
- Interfacial and peripheral seals : silicone rubber
- Contacts : machined copper alloy gold plated, 1.27 micron min gold over 2 microns min nickel on contact area  
Contact retention force :  
#22 : 45 Nmin - #16, #20 : 67 Nmin

### Environmental

Temperature	-55°C / + 125°C	MIL-STD 1344 method 1003 condition A NFC 20714
Sealing	Leakage < 16 cm <sup>3</sup> /h altitude immersion (8FD)	NFC 20717 with differential pressure of 2 bars MIL-STD 1344, method 1004
Humidity	10 cycles 24h 56 days	MIL-STD 1344, method 1002, type II except step 7b NFC 20703
Salt spray	48 h - L plating 500 h - B and W plating	MIL-STD 1344, method 1001, condition B NFC 20711 MIL-STD 1344, method 1001, condition C
Durability	500 cycles	mating/unmating
Vibrations	30 g (sinus) 41.7 Gms (random)	MIL-STD 202, method 204, condition G MIL-STD 1344, method 2005, condition VI, letter J
Shock	300 g 3 ms	MIL-STD 1344, method 2004, condition D

## Ordering information

<b>Basic series :</b>	<b>8 T F D 00 C 15 W 35 P N M ***</b>
- 8TFLT : 38999 Series I, HE308 type	
- 8TFD : 38999 Series III type	
<b>planar Array filter</b>	
<b>shell type</b>	00 - square flange receptacle 03 - square flange receptacle (rear mounting) (series 1 only) 07 - jam nut receptacle
<b>Termination</b>	— : solder bucket C : Straight spill
<b>shell size</b>	09 - 11 - 13 - 15 - 17 - 19 - 21 - 23 - 25
<b>Plating</b>	
8 TFLT : (series I)	B - 500 h salt spray green olive cadmium F - Nickel
8 TFD : (series III)	W - 500 h salt spray green olive cadmium F - Nickel
<b>contact layouts</b>	(see table page 341)
<b>contact type</b>	P - pin S - socket
<b>orientation</b>	8 TFLT : N - A - B - C - D 8 TFD : N - A - B - C - D - E
<b>filter type</b> (see page ???)	- capacitive BC, MC, TC, KC, EC - Pi type A, P, M, T, H
<b>special modifier</b>	- mixed filtering - specific filters - specific dimensions

# 8TFLT/8TFD



## Electrical characteristics capacitive filter types

Filter designation		BC	MC	TC	KC	EC
Filter type		Capacitive				
Max. voltage rating	# 22 # 20 # 16	200 Vdc 120 Vac rms 50 Hz or 400 Hz				
Max. current rating	# 22 # 20 # 16	5 A 7.5 A 13 A				
Insulation resistance, 25°C		> 5000 MΩ (under 100 VDC)				
DWV, sea level, 25°C		500 Vdc				
Contact resistance	# 22 # 20 # 16	17 mΩ 8,5 mΩ 4,5 mΩ				
Capacitance at 1kHz : 0.1Vrms at 25°C		12 000 pF to 24 000 pF	6 000 pF to 12 000 pF	3 000 pF to 6 000 pF	1 500 pF to 3 000 pF	350 pF to 750 pF
	frequency (MHz)	minimum attenuation (dB)				
Attenuation per MIL-STD-220 at 25°C (with no applied voltage or current, in 50 Ω system)	0.3					
	1	5	2			
	3	12	9	4	2	
	10	22	19	13	8	
	30	30	25	20	16	4
	100	40	35	30	25	12
	300	45	42	38	34	23
	1000	55	50	45	42	30









## Electrical characteristics for Pi filter types

Filter designation		A	P	M	T	H
Filter type		π Type				
Max. voltage rating	# 22 # 20 # 16	200 Vdc 120 Vac 50 Hz or 400 Hz				
Max. current rating	# 22 # 20 # 16	5 A 7.5 A 13 A				
Insulation resistance, 25°C, 2mn electrification time		> 5000 MΩ (under 100 VDC)				
DWV, sea level, 25°C		500 Vdc				
Contact resistance	# 22 # 20 # 16	17 mΩ 8,5 mΩ 4,5 mΩ				
Capacitance at 1kHz : 0.1Vrms at 25°C		24 000 pF to 48 000 pF	12 000 pF to 24 000 pF	6 000 pF to 12 000 pF	3 000 pF to 6 000 pF	700 pF to 1500 pF
	frequency (MHz)	minimum attenuation (dB)				
Attenuation per MIL-STD-220 at 25°C (with no applied voltage or current, in 50 Ω system)	0.3	2				
	1	8	5	2		
	3	15	10	7	3	
	10	38	28	18	9	2
	30	58	48	35	22	7
	100	65	60	55	45	24
	300	65	65	60	55	40
	1000	65	65	60	55	55

# 8TFLT/8TFD

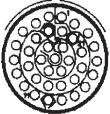

**Contact layouts - view from front face of male insulator**

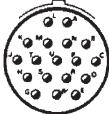
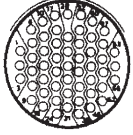
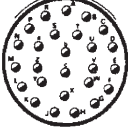
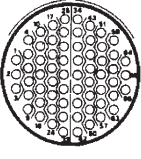
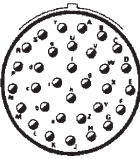
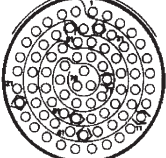
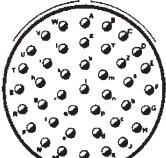
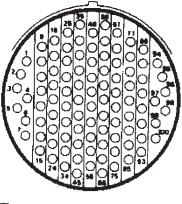
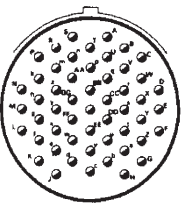
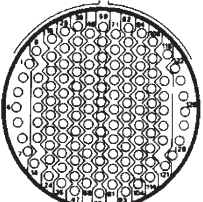
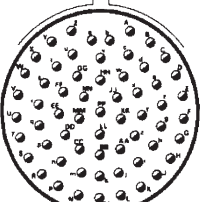
<b>shells</b> <b>09</b>	<b>09-35</b> 6 #22 	<b>09-98</b> 3 #20 	
	<b>11</b> <b>11-35</b> 13 #22 D 	<b>11-98</b> 6 #20 	
<b>13</b>	<b>13-35</b> 22 #22 D 	<b>13-98</b> 10 #20 	
	<b>15</b> <b>15-35</b> 37 #22 D 	<b>15-19</b> 19 #20 	<b>15-18</b> 18 #20 
<b>17</b> <b>17-35</b> 55 #22 D 	<b>17-26</b> 26 #20 		
<b>19</b>	<b>19-35</b> 66 #22 D 	<b>19-32</b> 32 #20 	
	<b>21</b> <b>21-35</b> 79 #22 D 	<b>21-41</b> 41 #20 	
<b>23</b>	<b>23-35</b> 100 #22 D 	<b>23-53</b> 53 #20 	
	<b>25</b> <b>25-35</b> 128 #22 D 	<b>25-61</b> 61 #20 	

# 8TFLT



## 8TFLT 00

Square flange receptacle, front mounting

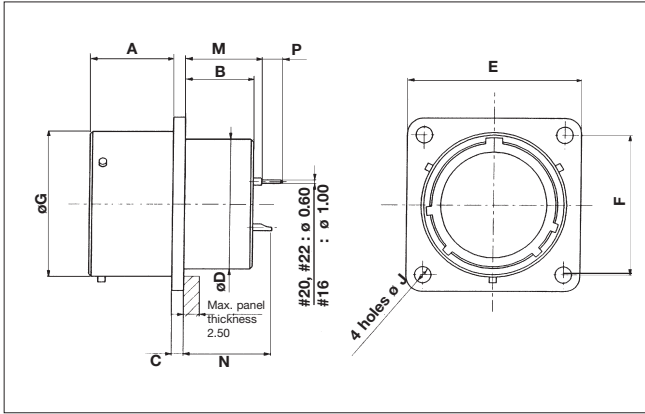

Dim.	Shell Size								
	09	11	13	15	17	19	21	23	25
<b>A Max</b>	16.05 .632	16.05 .632	16.05 .632	16.05 .632	16.05 .632	16.05 .632	15.29 .602	15.29 .602	15.29 .602
<b>B Max</b>	13.33 .525	13.33 .525	13.33 .525	13.33 .525	13.33 .525	13.33 .525	13.33 .525	13.33 .525	13.33 .525
<b>C Max</b>	2.48 .098	2.48 .098	2.48 .098	2.48 .098	2.48 .098	2.48 .098	3.24 .128	3.24 .128	3.24 .128
<b>D Max</b>	12.00 .472	15.00 .591	18.00 .709	22.00 .866	25.00 .984	28.00 1.102	31.00 1.220	34.00 1.339	37.00 1.457
<b>E</b>	23.95 .943	26.35 1.037	28.75 1.132	31.10 1.224	33.45 1.317	36.65 1.443	39.85 1.569	43.00 1.693	46.25 1.821
<b>F</b>	18.26 .719	20.62 .812	23.01 .906	24.61 .969	26.97 1.062	29.36 1.156	31.75 1.250	34.93 1.375	38.10 1.500
<b>G Max</b>	14.53 .572	17.78 .700	21.59 .850	24.77 .975	27.94 1.100	30.66 1.207	33.83 1.332	37.00 1.457	40.18 1.582
<b>J</b>	3.25 .128	3.25 .128	3.25 .128	3.25 .128	3.25 .128	3.25 .128	3.25 .128	3.73 .147	3.73 .147
<b>M</b>	14.75 .581	14.75 .581	14.75 .581	14.75 .581	14.75 .581	14.75 .581	14.75 .581	14.75 .581	14.75 .581
<b>N</b>	16.90 .665	16.90 .665	16.90 .665	16.90 .665	16.90 .665	16.90 .665	16.90 .665	16.90 .665	16.90 .665
<b>P</b>	# 20 5.60 .220	5.60 .220	5.60 .220	5.60 .220	5.60 .220	5.60 .220	5.60 .220	5.60 .220	5.60 .220
	# 22 7.20 .283	7.20 .283	7.20 .283	7.20 .283	7.20 .283	7.20 .283	7.20 .283	7.20 .283	7.20 .283

## 8TFLT 03

Square flange receptacle, rear mounting

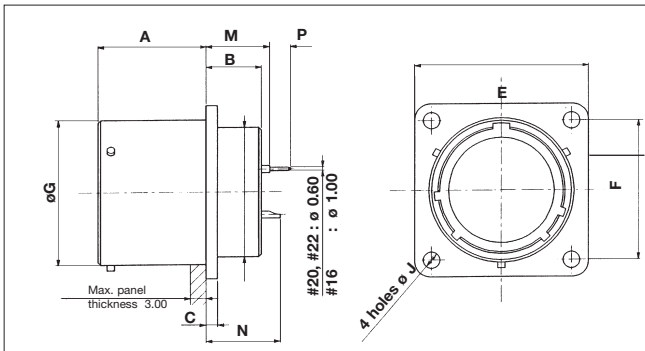

Dim.	Shell Size								
	09	11	13	15	17	19	21	23	25
<b>A Max</b>	20.83 .820	20.83 .820	20.83 .820	20.83 .820	20.83 .820	20.83 .820	20.08 .791	20.08 .791	20.08 .791
<b>B Max</b>	10.54 .415	10.54 .415	10.54 .415	10.54 .415	10.54 .415	10.54 .415	11.29 .444	11.29 .444	11.29 .444
<b>C Max</b>	2.48 .098	2.48 .098	2.48 .098	2.48 .098	2.48 .098	2.48 .098	3.24 .128	3.24 .128	3.24 .128
<b>D Max</b>	12.00 .472	15.00 .591	18.00 .709	22.00 .866	25.00 .984	28.00 1.102	31.00 1.220	34.00 1.339	37.00 1.457
<b>E</b>	23.95 .943	26.35 1.037	28.75 1.132	31.10 1.224	33.45 1.317	36.65 1.443	39.85 1.569	43.00 1.693	46.25 1.821
<b>F</b>	18.26 .719	20.62 .812	23.01 .906	24.61 .969	26.97 1.062	29.36 1.156	31.75 1.250	34.93 1.375	38.10 1.500
<b>G Max</b>	14.53 .572	17.78 .700	21.59 .850	24.77 .975	27.94 1.100	30.66 1.207	33.83 1.332	37.00 1.457	40.18 1.582
<b>J</b>	3.25 .128	3.25 .128	3.25 .128	3.25 .128	3.25 .128	3.25 .128	3.25 .128	3.73 .147	3.73 .147
<b>M</b>	12.15 .478	12.15 .478	12.15 .478	12.15 .478	12.15 .478	12.15 .478	12.91 .508	12.91 .508	12.91 .508
<b>N</b>	14.32 .564	14.32 .564	14.32 .564	14.32 .564	14.32 .564	14.32 .564	15.08 .594	15.08 .594	15.08 .594
<b>P</b>	# 20 5.60 .220	5.60 .220	5.60 .220	5.60 .220	5.60 .220	5.60 .220	5.60 .220	5.60 .220	5.60 .220
	# 22 7.20 .283	7.20 .283	7.20 .283	7.20 .283	7.20 .283	7.20 .283	7.20 .283	7.20 .283	7.20 .283

Dim.	Shell Size								
	09	11	13	15	17	19	21	23	25
<b>A Max</b>	23.36 .920	23.36 .920	23.36 .920	23.36 .920	23.36 .920	23.36 .920	23.36 .920	23.36 .920	23.36 .920
<b>B Max</b>	8.32 .328	8.32 .328	8.32 .328	8.32 .328	8.32 .328	8.32 .328	8.32 .328	8.32 .328	8.32 .328
<b>C Max</b>	3.00 .118	3.00 .118	3.00 .118	3.00 .118	3.00 .118	3.00 .118	3.79 .149	3.79 .149	3.79 .149
<b>D Max</b>	12.00 .472	15.00 .591	18.00 .709	22.00 .866	25.00 .984	28.00 1.102	31.00 1.220	34.00 1.339	37.00 1.457
<b>E Max</b>	22.35 .880	25.55 1.006	30.30 1.193	33.45 1.317	36.65 1.443	39.80 1.567	43.00 1.693	46.15 1.817	50.95 2.006
<b>F</b>	27.00 1.063	31.75 1.250	34.95 1.376	38.15 1.502	41.30 1.626	46.02 1.812	49.24 1.939	52.40 2.063	55.58 2.188
<b>G Max</b>	14.53 .572	17.78 .700	21.59 .850	24.77 .975	27.94 1.100	30.66 1.207	33.83 1.332	37.00 1.457	40.18 1.582
<b>J</b>	30.25 1.191	34.95 1.376	38.10 1.500	41.35 1.628	44.45 1.750	49.25 1.939	52.35 2.061	55.65 2.191	58.72 2.312
<b>M</b>	9.68 .381	9.68 .381	9.68 .381	9.68 .381	9.68 .381	9.68 .381	9.68 .381	9.68 .381	9.68 .381
<b>N</b>	11.83 .466	11.83 .466	11.83 .466	11.83 .466	11.83 .466	11.83 .466	11.83 .466	11.83 .466	11.83 .466
<b>P</b>	# 20 5.60 .220	5.60 .220	5.60 .220	5.60 .220	5.60 .220	5.60 .220	5.60 .220	5.60 .220	5.60 .220
	# 22 7.20 .283	7.20 .283	7.20 .283	7.20 .283	7.20 .283	7.20 .283	7.20 .283	7.20 .283	7.20 .283

## 8TFLT 07

Jam nut receptacle

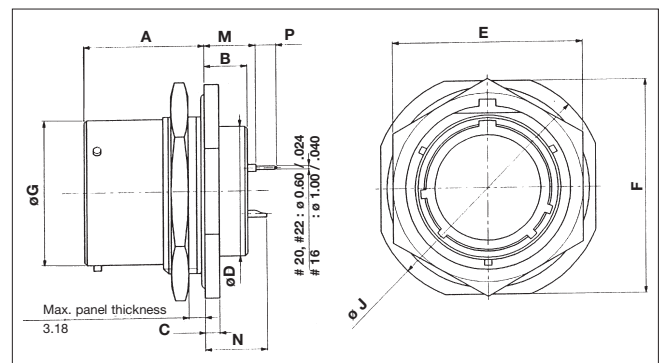

# 8TFD



## 8TFD 00

Square flange receptacle, front mounting

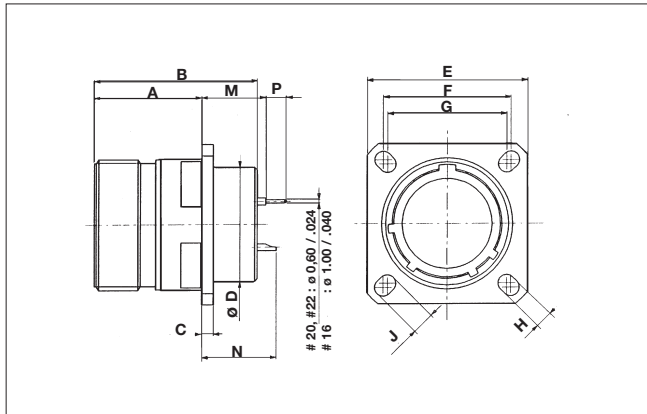

Dim.	Shell Size								
	09	11	13	15	17	19	21	23	25
<b>A Max</b>	20.90 .823	20.90 .823	20.90 .823	20.90 .823	20.90 .823	20.90 .823	20.10 .791	20.10 .791	20.10 .791
<b>B Max</b>	31.50 1.240	31.50 1.240	31.50 1.240	31.50 1.240	31.50 1.240	31.50 1.240	31.50 1.240	31.50 1.240	31.50 1.240
<b>C Max</b>	2.50 .098	2.50 .098	2.50 .098	2.50 .098	2.50 .098	2.50 .098	3.20 .126	3.20 .126	3.20 .126
<b>D Max</b>	12.00 .472	15.00 .591	18.50 .728	22.00 .866	25.00 .984	28.00 1.102	31.00 1.220	34.00 1.339	37.00 1.457
<b>E</b>	23.80 .937	26.20 1.031	28.60 1.126	31.00 1.220	33.30 1.311	36.50 1.437	39.70 1.563	42.90 1.689	46.00 1.811
<b>F</b>	18.26 .719	20.62 .812	23.01 .906	24.61 .969	26.97 1.062	29.36 1.156	31.75 1.250	34.93 1.375	38.10 1.500
<b>G</b>	15.09 .594	18.26 .719	20.62 .812	23.01 .906	24.61 .969	26.97 1.062	29.36 1.156	31.75 1.250	34.93 1.375
<b>H</b>	3.25 .128	3.25 .128	3.25 .128	3.25 .128	3.25 .128	3.25 .128	3.25 .128	3.91 .154	3.91 .154
<b>J Max</b>	5.49 .216	4.93 .194	4.93 .194	4.93 .194	4.93 .194	4.93 .194	4.93 .194	6.15 .242	6.15 .242
<b>M</b>	12.35 .486	12.35 .486	12.35 .486	12.35 .486	12.35 .486	12.35 .486	13.15 .518	13.15 .518	13.15 .518
<b>N</b>	14.50 .571	14.50 .571	14.50 .571	14.50 .571	14.50 .571	14.50 .571	15.30 .602	15.30 .602	15.30 .602
<b>P</b>	#20 5.60 #16 .220	5.60 .220	5.60 .220	5.60 .220	5.60 .220	5.60 .220	5.60 .220	5.60 .220	5.60 .220
	#22 7.20 .283	7.20 .283	7.20 .283	7.20 .283	7.20 .283	7.20 .283	7.20 .283	7.20 .283	7.20 .283

## 8TFD 07

Jam nut receptacle

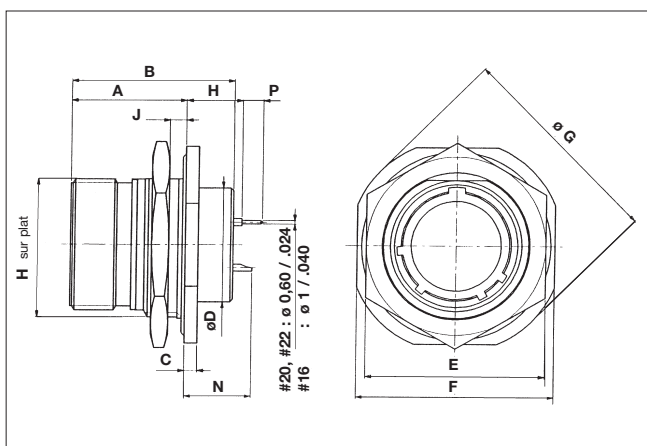

Dim.	Shell Size								
	09	11	13	15	17	19	21	23	25
<b>A Max</b>	22.25 .876	22.25 .876	22.40 .882	22.40 .882	22.40 .882	22.40 .882	22.40 .882	22.40 .882	22.40 .882
<b>B Max</b>	31.50 1.240	31.50 1.240	31.50 1.240	31.50 1.240	31.50 1.240	31.50 1.240	31.50 1.240	31.50 1.240	31.50 1.240
<b>C Max</b>	2.70 .106	2.70 .106	2.70 .106	2.70 .106	2.70 .106	2.70 .106	3.50 .138	3.50 .138	3.50 .138
<b>D Max</b>	12.00 .472	15.00 .591	18.00 .709	22.00 .866	25.00 .984	28.00 1.102	31.00 1.220	34.00 1.339	37.00 1.457
<b>E Max</b>	24.00 .945	27.00 1.063	32.00 1.260	36.00 1.417	37.00 1.457	41.00 1.614	46.00 1.811	50.00 1.969	51.23 2.017
<b>F</b>	27.00 1.063	31.80 1.252	34.90 1.374	38.10 1.500	41.30 1.626	46.00 1.811	49.20 1.937	52.40 2.063	55.60 2.189
<b>G</b>	30.20 1.189	34.90 1.374	38.10 1.500	41.30 1.626	44.50 1.752	49.20 1.937	52.40 2.063	55.60 2.189	58.70 2.311
<b>H</b>	16.53 .651	19.07 .751	23.82 .938	26.97 1.062	30.15 1.187	33.32 1.312	36.50 1.437	39.67 1.562	42.85 1.687
<b>J</b>	3.20 .126	3.20 .126	3.20 .126	3.20 .126	3.20 .126	3.20 .126	3.20 .126	3.20 .126	3.20 .126
<b>M</b>	11.00 .433	11.00 .433	10.80 .425	10.80 .425	10.80 .425	10.80 .425	10.80 .425	10.80 .425	10.80 .425
<b>N</b>	13.13 .517	13.13 .517	12.95 .510	12.95 .510	12.95 .510	12.95 .510	12.95 .510	12.95 .510	12.95 .510
<b>P</b>	#20 5.60 #16 .220	5.60 .220	5.60 .220	5.60 .220	5.60 .220	5.60 .220	5.60 .220	5.60 .220	5.60 .220
	#22 7.20 .283	7.20 .283	7.20 .283	7.20 .283	7.20 .283	7.20 .283	7.20 .283	7.20 .283	7.20 .283