

## KC2100 Series

EMC Circular Backshell for high levels of EMC screening and environmental sealing inc. TEMPEST

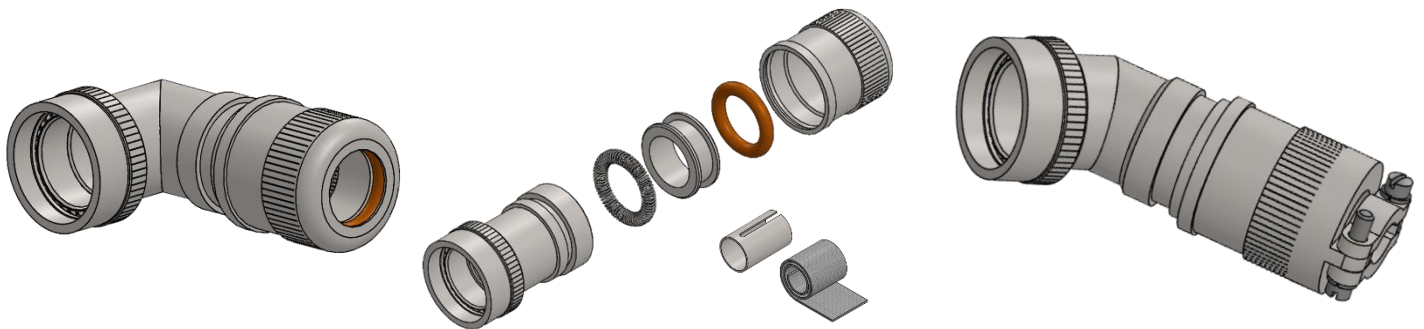

- Suitable for all standard circular connectors
- High levels of EMC and environmental performance including TEMPEST
- Overall screening is provided by proven IRIS spring technology
- Individual screening with slotted tube and braid kit
- Cable sealing up to IP68 depending upon 'O' ring seal option
- No special tools are required and the system is easily reworked
- Teeth on backshell body mesh with connector teeth for positive lock
- Blind teeth for increased screening capability
- Blind teeth for increased EMC screening with internal taper for enhanced environmental sealing with the connector
- Overall environmental seal is equal to or higher than the IP rating of the connector
- Ideal solution for fibre or mixed fibre and copper cable providing EMC screening and protection for the fibre

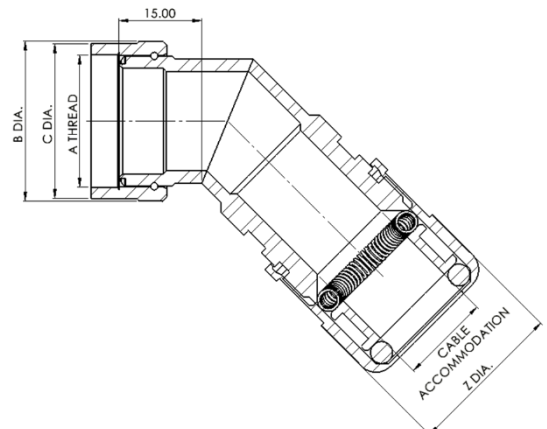
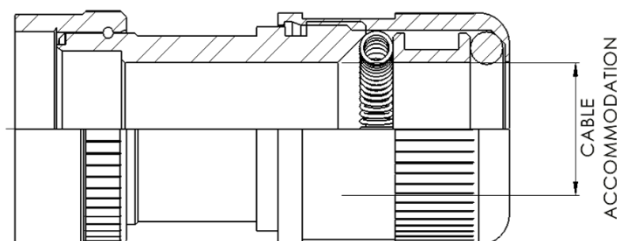
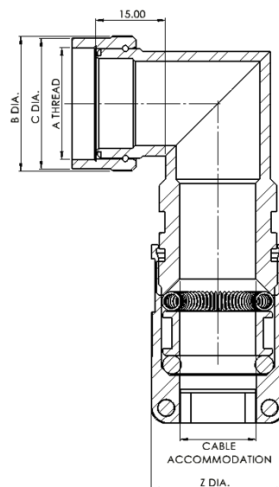
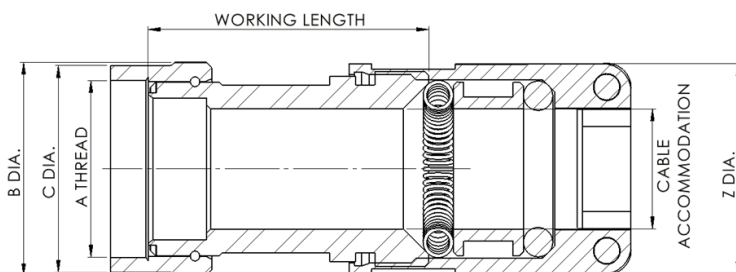

### KEC LIMITED

Orpheus House, Calleva Park, Aldermaston, Reading, Berkshire RG7 8TA England

[www.kec.co.uk](http://www.kec.co.uk)

Tel: +44 (0)118 981 1571 email: [sales@kec.co.uk](mailto:sales@kec.co.uk)

## EXAMPLE PART NUMBER

**KC2101 - 32 – 25D06C2W - K1 - XXX**

Material - Table 1

Connector Series - Table 3

Shell Size - Table 2

Function – Table 5

Cable Entry - Table 4

Clamp Options – Table 7

Working Length – Note 2

Finish – Table 6

Tube and Braid Kit  
(see Note 1)

Mod Code

TABLE 1	
MATERIAL CODE	
01	ALUMINIUM
02	STAINLESS STEEL
03	ALI BRONZE

TABLE 2					
SHELL SIZE	A THREAD 22/26/38 SERIES	A THREAD 28 SERIES	A THREAD 32 SERIES	B DIA MAX	C DIA MAX
08/09	7/16" - 28 UNEF	1/2" - 20 UNF	M12 x 1.00-6H	18.00	15.95
10/11	9/16" - 24 UNEF	5/8" - 24 UNEF	M15 x 1.00-6H	21.20	18.95
12/13	11/16" - 24 UNEF	3/4" - 20 UNEF	M18 x 1.00-6H	23.10	21.65
14/15	13/16" - 20 UNEF	7/8" - 20 UNEF	M22 x 1.00-6H	26.60	25.40
16/17	15/16" - 20 UNEF	1.000" - 20 UNEF	M25 x 1.00-6H	29.10	28.15
18/19	1 1/16" - 18 UNEF	1 1/16" - 18 UNEF	M28 x 1.00-6H	32.40	30.40
20/21	1 3/16" - 18 UNEF	1 3/16" - 18 UNEF	M31 x 1.00-6H	34.60	33.95
22/23	1 5/16" - 18 UNEF	1 5/16" - 18 UNEF	M34 x 1.00-6H	38.10	36.70
24/25	1 7/16" - 18 UNEF	1 7/16" - 18 UNEF	M37 x 1.00-6H	42.90	40.65

TABLE 3 (consult factory for other connector series options)				
SERIES CODE STRAIGHT	SERIES CODE 45° ANGLE	SERIES CODE 90° ANGLE	CONNECTOR TYPE (TYPICAL. MANY OTHER CONNECTOR TYPE OPTIONS AVAILABLE)	SHELL SIZE
22	42	82	MIL-C-26482 SERIES 1, PAT 105, 608, 603	08-24
26	46	86	MIL-C-38999 SERIES 1 & 2, PAT 614 & 616, PAN 6433-1	08-24
28	48	88	MIL-C-83723 SERIES 1 & 3, MIL-C-26482 SERIES 2 PAT 602 & PAN 6432-1 & 4	08-24
32	52	92	MIL-C-38999 SERIES III & IV, METRIC THREADS (EN3645)	09-25
38	58	98	PAN 6433-2, LN29729	08-24

TABLE 4				
ENTRY CODE	MIN mm	MAX mm	MAX K1/K2	Z DIA
01	1.6	3.2	N/A	15.9
02	3.2	6.4	N/A	19.1
03	6.4	9.5	3.75	22.3
04	9.5	12.7	6.90	25.4
05	12.7	15.9	10.1	28.6
06	15.9	19.1	13.2	31.9
07	19.1	22.2	15.9	35.0
08	22.2	25.4	19.1	38.1
09	25.4	28.6	22.3	41.3
10	28.6	31.8	23.6	44.5
11	31.8	34.9	24.9	47.7

TABLE 5	
FUNCTION	
D	EMI/RFI & ENVIRONMENTAL (IRIS/SEAL)
E	ENVIRONMENTAL & EMI/RFI (SEAL/IRIS)
F	EMP & TEMPEST (IRIS/IRIS)
G	HIGH PRESSURE SEAL (SEAL/SEAL)
T1	TEMPEST + ENVIRONMENTAL (IRIS/IRIS/SEAL)
T2	EMI/RFI HIGH PRESSURE SEAL (IRIS/SEAL/SEAL)

TABLE 6	
FINISH CODE	
G	BLACK ZINC NICKEL
J	ELECTROLESS NICKEL
W	CADMIUM + OLIVE DRAB
Z	ZINC COBALT + OLIVE DRAB

TABLE 7	
CLAMP OPTIONS	
C	WITH CLAMP BARS
N	WITHOUT CLAMP BARS

### NOTES:

- TUBE & BRAID KIT. OMIT IF NOT REQUIRED. PLEASE NOTE THAT TUBE & BRAID KITS ARE ONLY AVAILABLE FOR CABLE ENTRY SIZES 03 AND LARGER. BRAID WITHOUT TUBE CAN BE USED ON SIZE 02 TO TERMINATE INDIVIDUAL SCREENS. IF USING A KIT, DETERMINE THE CABLE ACCOMMODATION ENTRY SIZE FROM THE K1/K2 COLUMN IN TABLE 4. FOR MORE INFORMATION PLEASE CONSULT FACTORY.
- WORKING LENGTH IN 12.7mm (0.5in) INCREMENTS. FOR EXAMPLE WORKING LENGTH 4 = 50.8mm (2in). MINIMUM WORKING LENGTH FOR KC2100 SERIES IS 2. (STRAIGHT BACKSHELLS ONLY – OMIT ON ANGLED VERSIONS).

### KEC LIMITED

Orpheus House, Calleva Park, Aldermaston, Reading, Berkshire RG7 8TA England

www.kec.co.uk

Tel: +44 (0)118 981 1571 email: sales@kec.co.uk